

Raspberry Pi Pico 2 W – Compact Dual-Core Microcontroller with Built-in Wi-Fi and Bluetooth 5.2

Take your embedded and IoT projects to the next level with the **Raspberry Pi Pico 2 W** — the latest addition to the Raspberry Pi family of microcontrollers. Combining powerful processing, built-in wireless connectivity, and outstanding energy efficiency, this board is designed to make **IoT development, automation, and sensor integration** simpler and more powerful than ever before.

Whether you're an electronics hobbyist, educator, or embedded systems engineer, the Pico 2 W offers an exceptional balance of **performance, versatility, and affordability** in a remarkably compact size.

[caption id="attachment_108270" align="aligncenter" width="371"]

Raspberry Pi Pico 2 W[/caption]

Next-Generation Performance

At the heart of the **Raspberry Pi Pico 2 W** lies the new **RP2350 dual-core Arm Cortex-M33 processor**, delivering enhanced speed and security compared to the previous RP2040. Running at up to **150MHz**, it provides plenty of processing power for demanding embedded applications — from **real-time data acquisition** and **motor control** to **IoT communication** and **AI at the edge**.

The chip features advanced **TrustZone® security**, a **hardware floating-point unit (FPU)**, and **DMA channels** for efficient multitasking and precision timing, making it ideal for both professional and experimental projects.

[caption id="attachment_108271" align="aligncenter" width="411"]



Raspberry Pi Pico 2 W[/caption]

Built-in Wi-Fi and Bluetooth 5.2 Connectivity

The Raspberry Pi Pico 2 W introduces **native wireless capabilities**, featuring both **2.4GHz Wi-Fi** and **Bluetooth 5.2 (LE)**. This combination allows for **reliable, high-speed communication** and easy integration with smartphones, cloud services, and other IoT devices.

Wi-Fi connectivity enables remote data monitoring, firmware updates, and real-time cloud communication, while Bluetooth 5.2 allows for **low-energy device pairing** — perfect for **wearables, wireless sensors, and smart home devices**.

Thanks to its integrated antenna and optimized RF design, the Pico 2 W offers **stable, long-range wireless performance** while maintaining low power consumption.

Extensive I/O and Interfacing Options

Despite its small size, the Pico 2 W provides **26 multifunction GPIO pins**, giving developers the flexibility to connect a wide range of components and peripherals. The board supports key communication protocols including **UART, SPI, I²C, PWM, and ADC**, enabling easy interfacing with sensors, actuators, and other modules.

It also includes **three 12-bit ADC channels**, allowing precise analog data measurement for projects like **temperature monitoring, voltage sensing, and environmental data collection**.

With support for multiple serial interfaces and user-programmable I/O pins, the Pico 2 W is ideal for **robotics, automation, and data-logging applications**.

Power Efficiency and Robust Design

Designed for low-power operation, the **Raspberry Pi Pico 2 W** runs on a **1.8–5.5V DC input**, making it compatible with USB, battery, or external regulated power sources. Its energy-efficient architecture allows it to operate for extended periods on minimal power, making it perfect for **portable and battery-powered IoT devices**.

The board's **extended temperature range (-20°C to +85°C)** ensures reliable performance in both indoor and outdoor environments, from industrial settings to field deployments.

This robustness makes the Pico 2 W a dependable choice for **commercial products, embedded prototypes, and research projects**.

Compact and Practical Form Factor

Measuring just **21 mm × 51 mm**, the Raspberry Pi Pico 2 W fits effortlessly into tight spaces and compact enclosures. Its standard 40-pin layout maintains compatibility with accessories and breakout boards designed for the original Pico, ensuring **easy upgrades and backward compatibility** for existing designs.

The board features **castellated edges**, enabling straightforward soldering onto custom PCBs for professional or production-level integration.

Developer-Friendly and Open Source

Like all Raspberry Pi boards, the Pico 2 W is backed by an extensive **open-source ecosystem**. Developers can program it using **C/C++, MicroPython, or CircuitPython**, with comprehensive documentation and examples available from the Raspberry Pi Foundation.

The addition of wireless connectivity means developers can now build **connected IoT applications** directly on the Pico platform — such as **remote sensors, home automation systems, wireless data loggers, and smart devices** — without the need for external modules.

[caption id="attachment_108272" align="aligncenter" width="624"]

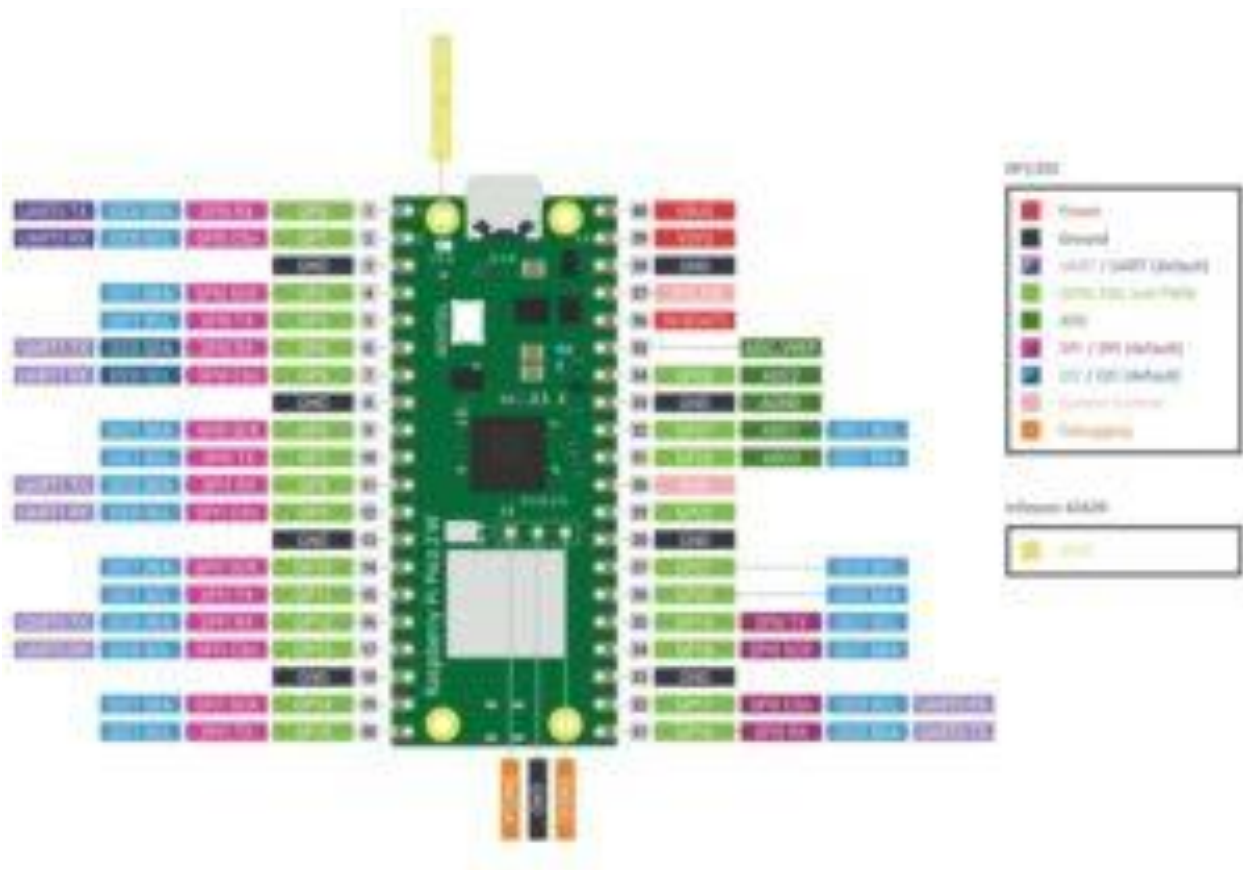

Raspberry Pi Pico 2 W [caption]

Key Specifications

- **Processor:** Dual-core Arm Cortex-M33 RP2350 @ up to 150MHz
- **Wireless:** 2.4GHz Wi-Fi and Bluetooth 5.2 (LE)
- **GPIO:** 26 pins (including ADC, UART, SPI, I2C, PWM)
- **Power Supply:** 1.8V–5.5V DC
- **Operating Temperature:** -20°C to +85°C
- **Memory:** 520KB SRAM, 4MB Flash
- **Form Factor:** 21 mm × 51 mm
- **Programming Languages:** C/C++, MicroPython, CircuitPython
- **USB Interface:** Micro-USB for power and data
- **Mounting:** Castellated edges for soldering on PCBs

Applications

- **IoT Devices and Wireless Sensors**
- **Smart Home Systems**
- **Robotics and Automation Projects**
- **Wearables and Portable Gadgets**
- **Remote Data Acquisition and Telemetry**
- **STEM Education and Learning Kits**
- **Industrial and Environmental Monitoring**

Why Choose the Raspberry Pi Pico 2 W

The **Raspberry Pi Pico 2 W** represents a new generation of microcontrollers — combining **powerful dual-core processing, integrated Wi-Fi and Bluetooth**, and **excellent power efficiency** in an affordable, compact design.

It's the perfect choice for developers looking to prototype IoT systems, automate processes, or build connected devices with minimal complexity. With extensive community support and open-source software compatibility, the Pico 2 W is ready to power the next wave of **intelligent, connected projects**.