

# ESP8266-12E WiFi Serial TTL Module – Powerful IoT Wireless Solution

The **ESP8266-12E WiFi Serial TTL Module** is a compact yet powerful wireless transceiver designed for Internet of Things (IoT) projects, home automation systems, and embedded applications. Powered by the **ESP8266EX SoC**, this module combines a **32-bit microcontroller**, integrated Wi-Fi functionality, and a full TCP/IP protocol stack in one small package. With its ease of use, low cost, and wide community support, the ESP8266-12E has become one of the most popular choices for makers, students, and professionals developing wireless projects.



## ◆ Built on the ESP8266EX Chip

At the heart of the ESP8266-12E lies the **ESP8266EX SoC**. This 32-bit microcontroller runs at 80/160 MHz and offers exceptional performance for handling both application logic and Wi-Fi communication. Its low power consumption and high efficiency make it ideal for battery-operated IoT devices and always-on wireless applications.

## ◆ Integrated Wi-Fi Connectivity

The ESP8266-12E comes with built-in support for **802.11 b/g/n Wi-Fi standards** and supports multiple modes of operation:

- **Station Mode** – Connects the module to an existing Wi-Fi network.

- **Access Point Mode** – Creates a standalone Wi-Fi hotspot for other devices.
- **Station + AP Mode** – Allows simultaneous use of both modes for advanced applications.

This flexibility ensures seamless integration into smart devices, cloud-connected systems, or peer-to-peer communication networks.

#### ◆ Serial TTL Interface for Easy Communication

The ESP8266-12E features a **UART (Serial TTL) interface**, making it easy to connect with microcontrollers like **Arduino, STM32, or Raspberry Pi**. With just a few simple AT commands, developers can establish wireless communication, exchange data, or set up web servers. This makes the ESP8266-12E perfect for both beginners and advanced developers.

#### ◆ Expanded GPIO for More Possibilities

Compared to earlier ESP8266 modules, the **ESP8266-12E** provides a wider set of **GPIO pins** for sensors, actuators, and peripheral connections. This allows you to:

- Connect sensors (temperature, humidity, motion, light).
- Control actuators like relays, motors, or LEDs.
- Interface with displays, memory devices, and other digital components.

This expanded I/O capability makes the 12E module more versatile than its predecessors, offering greater flexibility for complex projects.

#### ◆ Supported Programming Environments

The ESP8266-12E can be programmed in multiple ways, depending on your preferences and project requirements:

- **Arduino IDE** – Beginner-friendly and widely supported.
- **AT Commands** – Simple setup for Wi-Fi communication and control.
- **NodeMCU (Lua scripting)** – Lightweight scripting for rapid development.
- **MicroPython** – For Python developers exploring embedded systems.
- **PlatformIO / Native SDK** – Advanced programming with full control.

With such flexibility, the ESP8266-12E caters to both hobbyists and professionals.

## ◆ Key Features

- **Chipset:** ESP8266EX SoC
- **CPU:** 32-bit RISC, 80/160 MHz
- **Flash Memory:** 4MB (varies by version)
- **Wi-Fi Standards:** IEEE 802.11 b/g/n
- **Wi-Fi Modes:** Station / Access Point / Station+AP
- **Security:** WPA/WPA2
- **Interfaces:** UART, SPI, I2C, PWM, ADC, GPIO
- **Operating Voltage:** 3.0V – 3.6V (recommended 3.3V)
- **Power Consumption:** Ultra-low power modes supported
- **Form Factor:** Compact, with metal shielding for stable operation

## ◆ Applications

The ESP8266-12E WiFi Serial TTL Module is highly versatile and can be used in a wide range of IoT and wireless communication projects, including:

- **Smart Home Devices** – Control appliances, lighting, and security systems.
- **Wireless Sensor Networks** – Collect and transmit environmental data.
- **Remote Monitoring** – Send data to cloud platforms for analysis.
- **DIY IoT Projects** – Prototyping smart gadgets and connected systems.
- **Education & Research** – Teaching students about networking and embedded development.

## Pin Configuration and Functions

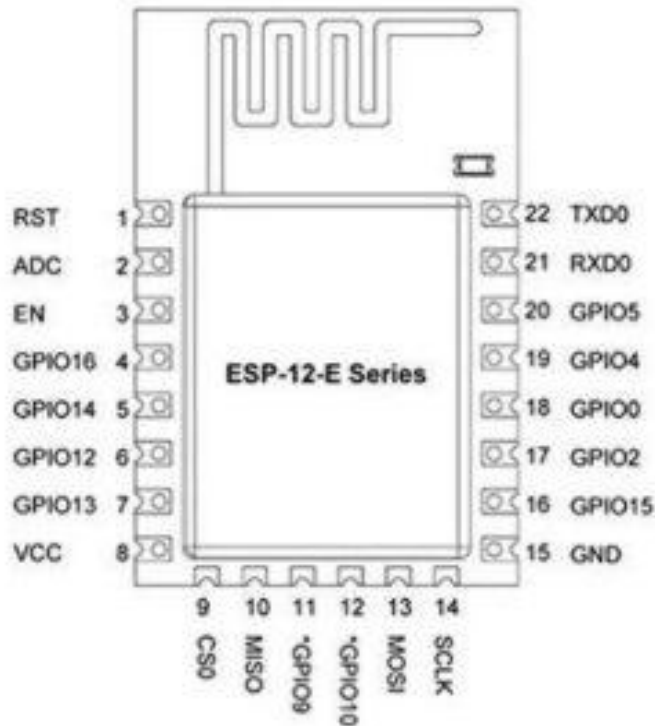

### Why Choose ESP8266-12E?

The ESP8266-12E stands out due to its **low cost, wide adoption, and powerful features**. Its large online community provides countless tutorials, libraries, and open-source projects, making it easy to find support and resources. With integrated Wi-Fi, expanded GPIO, and versatile programming options, this module remains one of the best solutions for building wireless IoT applications.

✓ **In summary**, the **ESP8266-12E WiFi Serial TTL Module** is a powerful, cost-effective, and flexible solution for IoT and embedded systems. Its compact size, integrated Wi-Fi, and expanded GPIO make it perfect for smart home projects, prototyping, and wireless communication applications. Whether you're just starting out or working on advanced IoT systems, the ESP8266-12E gives you the tools to bring your ideas to life.